



Digital Camera

Q40

USER MANUAL



Questions?
Need some help?
This manual will help you
enjoy your new product



If you still have questions
call our help line:
1-877-456-6055



or visit us at:
www.polaroid.com

Let's Get Started▶

Do not expose the camera's battery pack or other accessories to rain or humidity to prevent a fire hazard or electric shock.

For customers in the U.S.A.

Tested To Comply With FCC Standards FOR HOME OR OFFICE USE

FCC Statement

This device complies with part 15 of the FCC Rules. Operation is subject to the following two conditions:

- (1) This device may not cause harmful interference, and
- (2) this device must accept any interference received, including interference that may cause undesired operation.

For customers in Europe



"CE" mark indicates that this product complies with the European requirements for safety, health, environment and customer protection. "CE" marked cameras are intended for sales in Europe.

Supplier's declaration of conformity



N13001

For compliance levels 1, 2 and 3 in Australia and Levels of Conformity 1, 2 and 3 in New Zealand.

As required by notices under:

- Section 182 of the Australian Radiocommunications Act 1992;
- Section 407 of the Australia Telecommunications Act 1989; and
- Section 134 of the New Zealand Radiocommunications Act 1989.



This symbol [crossed-out wheeled bin WEEE Annex IV] indicates separate collection of electrical and electronic waste in the European countries. Please do not throw the equipment into the waste. Please recycle and dispose of properly.

Declaration of Conformity

Model Name: Q40

Trade Name: Polaroid

Responsible Party: plawa-feinwerktechnik GmbH & Co. KG

Address: Bleichereistrasse 18, 73066 UHINGEN, Germany

Conforms to the following Standards:

EMC: EN 55022:2006/A1:2007 Class B
 EN 55024:1998/A1:2001/A2:2003
 EN 61000-3-2:2006/A1:2009/A2:2009
 EN 61000-3-3:2008

following the provision of the EMC Directive (89/336/EEC, 2004/108/EEC)

Camera notes:

- !** Do not store or use the camera in the following environments:
 - In the rain, in humid or dusty environments.
 - In a place where the camera can be exposed directly to sunlight or subject to high temperatures, e.g. Inside a closed car in summer.
 - In a place where the camera is subject to a high magnetic field, e.g. near motors, transformers or magnets.
- !** Do not place the camera on a wet surface or places where dripping water or sand may come in contact with the camera.
- !** If the camera will not be used for a long period of time, remove the battery and the memory card from the camera and store them in a dry environment.
- !** If you carry the camera suddenly from a cold location to a warm place, moisture may condense inside the camera. It is suggested that you wait for a while before turning on the camera.
- !** The warranty does not cover any type of data loss or corruption.

Battery notes:

- !** Incorrect use of the battery may cause it to leak, become hot, ignite or burst. Always observe the following precautions.
 - Do not expose the battery to water, and take particular care to keep the terminals dry.
 - Do not heat the Battery or throw it into a fire.
 - Do not attempt to deform, disassemble or modify the battery.
- !** Keep the battery out of reach of babies and small children.
- !** In cold locations, battery performance deteriorates and battery life is significantly shortened.

Memory card notes:

- !** When using a new memory card, be sure to format the card with your digital camera before using it.
- !** Do not change or delete the folder names or file names in the memory card from your PC or, the camera may not be able to display those edited files on its LCD screen. To edit image data, copy the image data to the PC's hard disk first.
- !** The photos taken by this camera are stored in the auto-generated folder in the SD card. Please do not store photos that are not taken by this model of camera, as this may make it impossible to recognize the picture when the camera is in playback mode.

Preface

Thank you for purchasing this digital camera. Please read this manual carefully and keep it in a safe place for future reference.

Copyright

Copyright © 2011 All rights reserved This product is manufactured, distributed, and sold by plawa-feinwerktechnik GmbH & Co. KG, Bleichereistrasse 18, 73066 Uhingen, Germany.

No part of this publication may be reproduced, transmitted, transcribed, stored in a retrieval system, or translated into any language or computer language, in any form, by any means, without the prior written permission of plawa-feinwerktechnik GmbH & Co. KG.

Trademarks

All trademarks mentioned in this manual are used for identification purposes only and are properties of their respective owners.

Safety Information

Please read the following important information carefully before using this product.

- Do not take apart or attempt to service the camera yourself.
- Do not drop or knock the camera. Improper handling may damage the product.
- Turn off the camera before inserting or removing the battery and memory card.
- Use only the type of battery that comes with the camera. Using other types of batteries may damage the camera and void the warranty.
- Do not touch the camera lens.
- Please do not expose the camera to harsh environments such as moisture, or extreme temperatures, which may shorten the life of your camera or damage the battery.
- Do not operate or store the camera in dusty, dirty, or sandy environments.

- Do not expose the lens to direct sunlight for extended periods.
- Download all pictures and remove the batteries from the camera if you are going to store the camera for long periods of time.
- Do not use abrasive cleansers, alcohol-based, or solvent-based cleaners to clean the camera. To clean, wipe the camera with a slightly damp soft cloth.

About This Manual

This manual provides you with instructions on how to use your digital camera. Every effort has been made to ensure that the contents of this manual are accurate, however plawa-feinwerktechnik GmbH & Co. KG reserves the right to make changes without notice.

Symbols used in this manual

Throughout this manual, the following symbols are used to help you locate information quickly and easily:



Indicates the useful information to know.



Indicates precautions to be taken while operating the camera.

WARNING	i	Using the Mode Button	14
SAFETY PRECAUTIONS	ii	Setting language and date/time	15
BEFORE YOU START	1	Setting the Language	15
Preface	1	Setting the Date and Time	16
Copyright	1	About the LCD Screen	17
Trademarks	1	BASIC OPERATION	18
Safety information	1	Shooting in Auto Mode	18
About this manual	2	Using the Zoom Function	18
Symbols used in this manual	2	Basic Functions Menu	19
CONTENTS	3	Flash	19
GETTING READY	7	Self-timer	20
Unpacking	7	Macro Mode	20
Camera Views	8	Exposure Compensation.....	20
Inserting the Battery and SD/SDHC Card (Not included)	10	Advanced Functions Menu	21
Charging the Battery	12	WB (White Balance)	22
Turning On and Off	13	ISO	22
		Quality	23
		Size	23
		Color	24

USING THE MODES	25	Museum	32
LCD Screen Display	25	Night Landscape	32
Still Picture Mode Display	25	Children	32
Video Shooting Mode Display	27	Leaf	33
Playback Mode Display	28	Sunset	33
Auto Scene Mode (ASCN)	29	Glass	33
Landscape	29	Landscape	33
Portrait	29	Night Portrait	33
Night Portrait	30	Beach	33
Backlit Portrait	30	Text	33
Night Landscape	30	Gathering	33
Macro	30	ID	33
Auto	30	Fish eye.....	33
Panorama	30	Travel shooting.....	33
Manual Scene Mode (SCN)	31	Photo frame.....	33
Sport	32	Sketch	33
Indoor	32	Blink Detection	34
Snow	32	Face Detection	35
Fireworks	32	Smile Detection	36

PLAYBACK	37	Expo Metering (Exposure Metering)	49
Viewing Photos and Videos	37	Playback Menu	50
Thumbnail View	39	Protect	50
Using Zoom on Playback (for still pictures only)	40	Delete	51
Using the Delete Button	41	DPOF (Digital Print Order Format)	52
USING THE MENUS	42	Trim	53
Still Picture Menu	42	HDR-High Dynamic Range.....	53
AF Mode (Auto-Focus mode)	43	Resize	54
AF-Assist Beam	43	Rotate	54
Continuous AF	44	Red-eye Reduction	55
Expo Metering (Exposure Metering)	44	Display Setup	55
Continuous Shot	45	Slideshow	56
Date Imprint	45	Wallpaper Settings	56
Quick Review	46	Setup Menu	59
Digital Zoom	46	Beep	60
Slow Shutter	47	LCD Brightness	60
Movie Menu	48	Power Saver	61
Continuous AF	49	Zone	61
		Date/Time	62

Language	62	APPENDICES	69
File and Software	62	Specifications	69
Format Memory.....	62	Error Messages	73
File Numbering	63	Troubleshooting	75
Copy to Card (Copy internal memory to memory card)	63	Customer Care	77
Reset Settings	64		
FW Version (Firmware version)	64		
Transmission.....	65		
Video System	65		
Connecting Your Camera to a HDMI TV to View Videos	66		
Connecting to a PC	67		
Setting the USB Mode	67		
Transferring Files to your PC	67		

Unpacking

Your package should contain the camera model you purchased along with the following items. If anything is missing or appears to be damaged, please contact your vendor.



Warranty Card

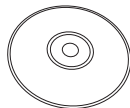

CD-ROM



Wrist Strap

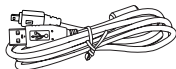

USB Cable

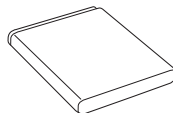

Rechargeable lithium-ion battery

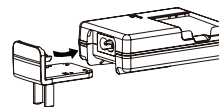

Battery charger

Camera Views

Front View

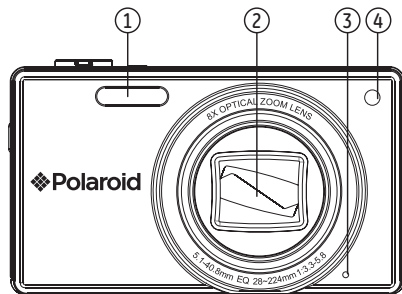

Back View

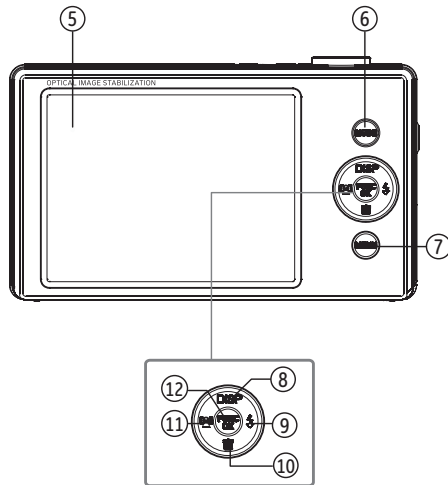

Right View

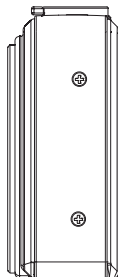

Top View

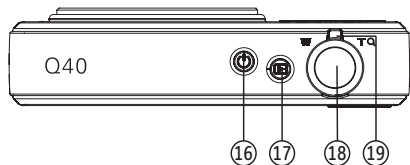

Bottom View

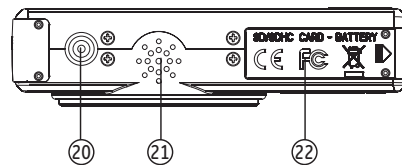

Left View

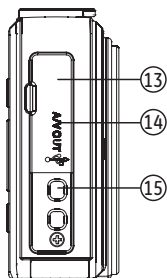

1	Flash	12	Function/OK Button
2	Lens	13	HDMI Port
3	Mic	14	USB/AV Port
4	AF assist beam/Timer indicator	15	Wrist Strap Mount
5	LCD Screen	16	Power Button
6	Mode Selection Button	17	Playback Button
7	Menu Button	18	Shutter Button
8	Disp/Up Button	19	Zoom Wheel
9	Flash Mode/Right Button	20	Tripod Mount Point
10	Delete Button/Down Button	21	Speaker
11	Face Detection/Left button	22	Memory Card/Battery Compartment

Insert the Battery and SD/SDHC Card (Not included)

1. Open the battery compartment.

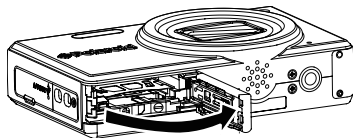
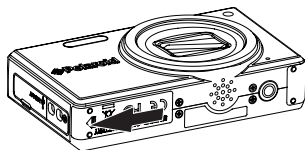

2. Insert the battery while observing the correct polarity. Use the side of battery to press down the stopper as shown, allowing the battery to lock into place properly.

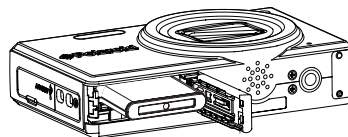
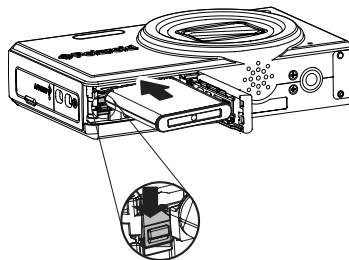

3. Insert an SD/SDHC card (not included) into the memory card slot as shown.

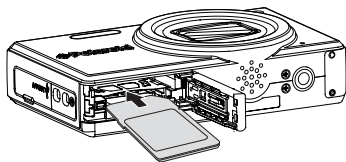

4. Close the battery compartment.

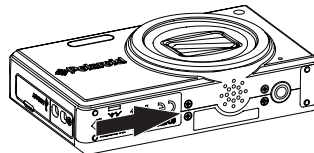
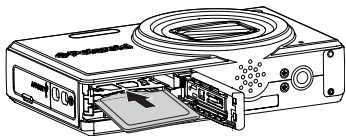
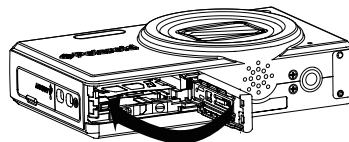

- Optional SD/SDHC cards are not included. The use of 64 MB to 32 GB memory cards from recognized manufacturers such as SanDisk, Panasonic and Toshiba are recommended for reliable data storage.
- To remove the SD/SDHC card, open the battery compartment and gently push the card to release it. Pull the card out carefully.

Charging the Battery

1. Place the battery into the charger as shown.
2. Plug the one end of the connecting cable (plug adapter) into the charger base.
3. Plug the other end of the connecting cable into a wall outlet.

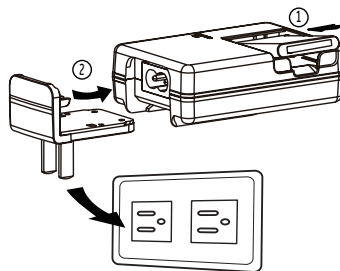

- ① Leave the battery charging until the charger light turns green. (To maximize battery life, the first charge should be at least 4 hours)
- ① The charger is for indoor use only.

Turning On and Off



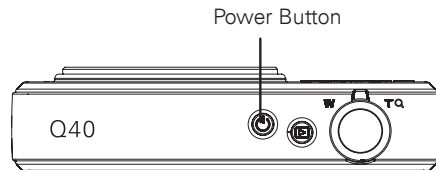



Press the Power button to turn the camera on. To turn off the camera, press the Power button again.



When the camera is turned on, it will default to the the shooting mode last used. You can use the Mode button on the back to change modes. When using the camera for the first-time, the language setup page will appear.

Using the Mode Button

The camera provides a convenient mode button that allows you to switch between different modes easily. After pressing the mode button to enter mode selection menu, press Left/Right button to choose the mode, press "func/OK" to select. All the available modes are listed as follows:

Mode Name	Icon	Description
Auto mode		The camera sets all the settings automatically.
Manual mode		Many of the camera settings can be configured manually in this mode.
Panorama mode		In this mode, up to 8 frames can be stitched together to create panoramic photo.
Scene mode	SCN	Choose from 20 different scene types and effects for your photos.
Movie mode		Switch to record videos.
ASCN mode		Switch to have the camera automatically select the best scene type for still pictures.
Portrait		Switch to take portrait pictures.

Setting Language and Date/Time

 The Date/Time and Language setup page will automatically appear when the camera is turned on the first time.



To set the display language and date/time, go to the following setup options in the General Setup menu.

- Language
- Date/Time

To access the **General Setup** menu, do the following:



1. Press the **Power** button to turn the camera on.
2. Press the  button, then switch among camera settings menus with the Left/Right button and select the General Setup menu. Then press the Up/Down button to access General Setup menu options.

Setting the Language

1. Select language with the Up/Down button, then press the  or right button to enter language options.
2. Use the Up/Down/Left/Right buttons to select the desired language.
3. Press the  button to confirm the setting.



Setting the Date and Time

1. Select date/time with Up/Down button, then press the  or right button to enter the date/time settings options.
2. Use the Left/Right button to select the date or time field, then press the Up/Down buttons to adjust the values.
3. Press the  button to confirm the setting.

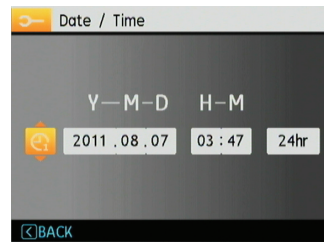

About the LCD Screen

When you turn the camera on, various icons are shown on the LCD screen to indicate the current camera settings and status. To learn more about the displayed icons, see “LCD Screen display” on page 25.

LCD Screen notes:

Extremely high-precision technology has been used to manufacture the LCD screen so that most of the pixels are operational for use. However, there may be some minute points (black, white, red, blue or green) that constantly appear on the LCD screen. These points are normal in the manufacturing process and the recorded image is not affected in any way.



Avoid exposing the LCD screen to water; please remove any moisture on the LCD screen with a soft dry cleaning cloth.



If the LCD monitor is damaged, take particular care with the liquid inside the monitor. If any of the following situations arise, take the recommended immediate action indicated below:

- If liquid from the LCD comes in contact with your skin, wipe the area with a cloth and then wash thoroughly with soap and running water.
- If liquid from the LCD flows into the eyes inadvertently, please rinse with water immediately and seek medical assistance.
- If liquid from the LCD is swallowed, flush your mouth thoroughly with water. Drink large quantities of water and induce vomiting. Then seek medical assistance immediately.

Shooting in Auto Mode

Auto mode is the easiest mode to take photos. While operating in this mode, the camera automatically optimizes your photos for best results.

To start shooting, do the following:

1. Press the **Power button** to turn the camera on.
2. In the Mode menu, select the Auto mode ().
3. Compose your picture in the LCD screen and press the Shutter button halfway to focus on the subject.
4. The focus frame in the middle of the LCD will turn to green when the subject is properly in focus.
5. Press the **Shutter button** fully to capture the image.

Using the Zoom Function

There are two built-in zoom functions: optical zoom and digital zoom. When taking photos, you can zoom in or out on an object using the zoom wheel.

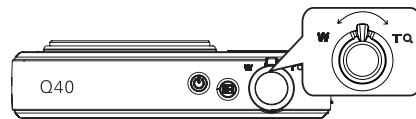

Zoom indicator
(See "Digital Zoom" on page 46)

When the optical zoom reaches its maximum value, it stops momentarily. Release and push the zoom wheel again, and the optical zoom will switch over to digital zoom automatically. After the adjustment, the zoom indication scale hides immediately, and the current zoom status is indicated by the following symbol .

Basic Functions Menu

The Basic Function Menus of the camera include Flash, Self-timer, Macro Capture, and Exposure Compensation.

Set the basic functions as per the following steps:

1. Pull up the Basic Function Menus by pressing the Right/Flash button.









2. Press the Down button to enter the basic functions selection screen, then press the Left/Right button to select the functions which need to be set.
3. Press Up/Down button to enter the basic functions setup screen.





4. After pressing Left/Right button to select the options which need to be set, press the  button to confirm the setting and quit the screen.

Flash



-  Flash: Auto
The flash will fire automatically in low lighting conditions.
-  Flash: Red-eye reduction
Red eye is caused by the subject looking directly at the flash and the resulting light reflecting off of the retina of the eye. Red eye is eliminated by firing a smaller initial flash prior to the main flash to cause the subject not to look directly at the flash.

-  Flash: Forced flash
The flash will fire with every shot.
-  Flash: Forced off
Flash is turned off.
-  Flash: Slow Synchro
This allows you to take pictures of people at night that clearly show the subject. The shutter is held open longer to allow more light to the image sensor.
-  Flash: Red-Eye+Slow Synchro
Using this mode for slow synchro shots with red-eye reduction.

Self-timer

-  Self-timer: 2 sec
A single picture is shot 2 seconds after the Shutter button is pressed.
-  Self-timer: 10 sec
A single picture is shot 10 seconds after the Shutter button is pressed.
-  Self-timer: Off
Disables the self-timer.

Macro Mode

-  Macro: On
Select this to focus on subjects 5cm from the lens.
-  Macro: Off
Select this option to disable Macro mode.

Exposure Compensation

The exposure compensation feature allows you to adjust the light exposure value and control the brightness of the photo.

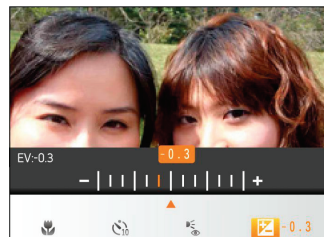

The adjustable range of exposure value is from EV -2.0 to EV+2.0.

Advanced Functions Menu

The Advanced Functions Menu of the camera include Image Size, Image Quality, White Balance, Image Color and ISO.

Set the advanced functions as follows.

1. Pull up the Advanced Function Menu by pressing the

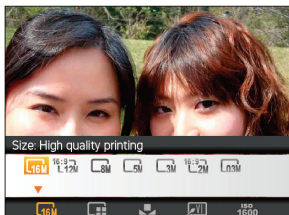
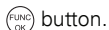

2. Press the Down button to enter the advanced function selection screen, press the Left/Right button to select the function that you want to set.
3. Press the Up button to enter the advanced function setting interface.









4. Use the Left/Right buttons to change the settings then press the  to confirm the new settings and close the Advanced Function Menu.

WB (White Balance)

The White Balance allows you to adjust the color temperature under different lighting conditions. (The WB setting is only available when the camera is in the **M** Manual mode).



The options of White Balance include:

-  WB: Auto
-  WB: Daylight
-  WB: Cloudy
-  WB: Fluorescent
-  WB: Fluorescent CWF
-  WB: Incandescent
-  WB: Manual (Press the shutter button to set WB.)

ISO

The ISO function allows you to set the sensitivity of the camera's sensor to light. To improve the performance in darker environments, a higher ISO value is required. On the other hand, a lower ISO value is needed when in bright conditions. (The ISO setting is only available when the camera is in the **M** Manual mode).

Pictures taken with higher ISO will generally have more noise than those taken with lower ISO.

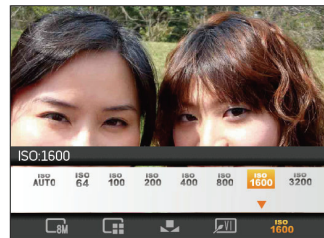

The options of ISO include automatic, 64, 100, 200, 400, 800, 1600 and 3200.



The available ISO values vary on different camera models.

Quality

The quality setting determines how much the camera compresses the photo files. The higher the compression, the smaller the file size will be, but the quality will decrease. The lower the compression, the larger the file size, but the better the quality.



The three levels of compression are:

-  : Quality: Best
-  : Quality: Fine
-  : Quality: Normal

Size

The size setting refers to the image resolution in pixels. A higher image resolution allows you to print that image in larger sizes without degrading the image quality.





The larger the pictures are, the bigger the file sizes are and the less pictures you can store on a memory card.

Color

The color setting option allows you to add artistic effects when taking pictures. You can try different color tones to alter the mood of your pictures. (The Color option is only available when the camera is in the **M** Manual mode).



The color options include:

-  Color: Auto
-  Color: Vivid
-  Color: Black & White
-  Color: Sepia

LCD Screen Display

Still Picture Mode Display

Mode:      

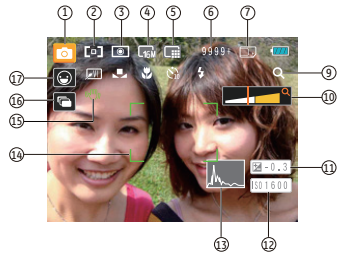

1 Shooting Mode Icons

 Auto mode

M Manual mode

 ASCN mode

SCN Scene mode

 Panorama mode

 Portrait

2 AF Mode

 Single-AF

 Multi-AF

3 Expo Metering





 Spot

 Center







 AiAE

4 Image Size

5 Image Quality

- 6 Remaining number of pictures
- 7 Memory card/built-in memory
- 8 Battery Status
- 9 WT Ratio (Displayed only when zoom is activated)
- 10 Zoom
- 11 Exposure
- 12 ISO Value (Adjustable only in  Manual Mode)
- 13 Histogram
- 14 Focus Frame
- 15 OIS
- 16 Continuous Shot / Slow Shutter Warning
- 17 Face Detection
- 18 Picture Color (Adjustable only in  Manual Mode)
- 19 White Balance (Adjustable only in  Manual Mode)
- 20 Macro Mode
- 21 Self-timer
 -  Self-timer: 2 sec
 -  Self-timer: 10 sec



22 Flash Mode

-  Flash: Auto
-  Flash: Red-eye reduction
-  Flash: Forced flash
-  Flash: Forced off
-  Flash: Slow Synchro
-  Flash: Red-Eye+Slow Synchro

Video Shooting Mode Display

Mode : 



- 1 Video Mode icon
- 2 Continuous AF
- 3 Metering
 -  Spot
 -  Center
 -  AiAE
- 4 Image Size
- 5 Focus Frame





- 6 Self-timer

 Self-timer: 10 sec

- 7 Remaining Time for Video Recording
- 8 Memory Card/Built-in Memory
- 9 Battery Status
- 10 WT Ratio (Displayed only when zoom is activated)
- 11 Zoom
- 12 Exposure
- 13 OIS
- 14 Recording Status Icon

 Recording standby

 Recording

-  In order to shoot video, it is recommended that an SD card be used.
-  When shooting video, the optical zoom is disabled.
-  HD recording time is limited to below 29min.
-  OIS is a function which is enabled by default unless deactivated by the user in either shooting or recording mode.

Playback Mode Display

Mode: 

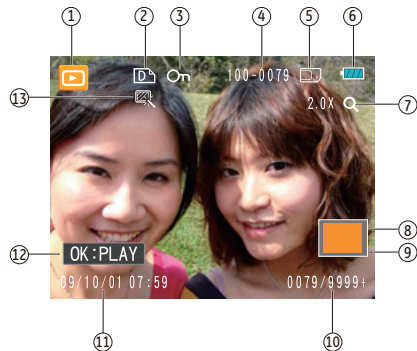

1. Playback Mode icon
2. DPOF file
3. File protection
4. Picture Number
5. Memory Card/Built-in Memory
6. Battery Status
7. Image Zoom
8. The current display area
9. Zoom magnification area shown
10. Memory Space (this picture/Total number of pictures)
11. Recording Date and Time
12. OK:PLAY
13. HDR

Auto Scene Mode (ASCN)







In the "ASCN" mode, different conditions are detected intelligently and the most suitable settings will be automatically selected.

To use "ASCN":

1. Press mode selection button and select ASCN mode, press the  button to enter ASCN mode, the LCD screen will display the detected scene icon as shown in the following figure:



2. Hold the camera steadily and aim at the subject. The optimum scene mode will be identified automatically.
3. Press the Shutter button halfway down to focus.
4. Press the Shutter button all the way down to take the picture.

Icon	Mode name	Icon	Mode name
	Landscape Mode		Night Landscape Mode
	Portrait Mode		Macro Mode
	Night Portrait		Auto Mode
	Backlit Portrait		

Landscape Mode

For landscapes, ASCN will automatically adjust the exposure to match the background.

Portrait Mode

For portraits, ASCN will automatically adjust the exposure and skin tones for more natural looking pictures.

Night Portrait

When you shoot portraits at night, or in low light conditions, ASCN will automatically adjust the exposure for people and night scenes.

Backlit Portrait

When the sun or any other light source is behind you, ASCN will automatically adjust the foreground exposure to produce good pictures.

Night Landscape Mode

For night scenes, ASCN will automatically increase the ISO value to compensate for low light.

Macro Mode

To capture object detail for close-ups, ASCN will automatically adjust the focus.



Auto Mode

The camera automatically adjusts the exposure and focus to ensure good pictures.

Panorama

Panorama mode allows you to create a panoramic picture by stitching together several pictures.

Follow these steps to create a panoramic picture:

1. Press the Mode button, use the Left/Right button to select Panorama mode, then press the  button to confirm the setting.
2. Use the Left/Right button to select the direction of image stitching, e.g. left to right or right to left. Then press the  button to confirm the setting; if no selection is made the camera will default to left to right stitching after 2 seconds.
3. After the first shot is taken, two target icons will appear on the left and right side of the LCD screen. Pan the camera and the circle icon on the screen in the specified direction and the circle will move towards the square frame icon. When the circle icon and square frame become green they will overlap, and the camera will capture the next picture automatically. You can repeat this process with up to 8 frames.



4. After taking 8 frames, the camera will stitch the images together automatically. Press the Playback button to view the final image.
- ⓘ After selecting Panorama mode, Flash, Self-timer, Macro mode and Exposure Compensation can't be adjusted.
 - ⓘ After taking a Panoramic picture press the func/ok button to save and exit or press the Delete button to cancel and exit.
 - ⓘ In Montage mode, up to 8 photos can be captured when the image size is set at 2MP.





















Manual Scene Mode (SCN)

In **Manual Scene** mode, you can select from a total of 20 scene types to match your needs. You just need to select the right scene for the occasion and the camera will automatically adjust to the optimal settings for you.

Press the Mode button, then use the Left/Right button to enter the Scene Selection mode menu, then press the FUNC/OK button to enter Scene Selection mode, the following figure will display on LCD screen:



Select a scene using the Up/Down/Left/Right button and press the  button.

Icon	Mode Name	Icon	Mode Name
	Sport		Indoor
	Snow		Fireworks
	Museum		Night Landscape
	Children		Leaf
	Sunset		Glass
	Landscape		Night Portrait
	Beach		Text
	Gathering		ID
	Fish eye		Travel shooting
	Photo frame		Sketch

Sport

For fast-moving subjects. Capture sharp action shots without blur.

Indoor

For indoors. Reduce blur and improve color accuracy.

Snow

For snow scenes. Reproduce natural and clear snow scenes.

Fireworks

For fireworks at night. Slow shutter speed adjusted for brilliant images. The use of a tripod is recommended.

Museum

For museum or flash-free areas. Retain color and reduce blur.

Night Landscape

For night scenes. The use of a tripod is recommended.

Children

For kids and pets. Flash is disabled for eye protection.

Leaf

For plants. Capture brilliant shots of greenery and blossoms.

Sunset

For sunsets. Capture subjects in strong sunlight.

Glass

For objects behind transparent glass.

Landscape

For landscapes. Vivid reproduction of green and blue.

Night Portrait

For portraits against night scenery.

Beach

For taking pictures in areas with strong sunlight.

Text

For taking pictures of text or documents or display boards.

Gathering

For taking pictures of people gathering indoors. Photos will appear natural even under difficult lighting conditions.

ID

Ideal to take pictures of documents such as IDs.

Fish eye

For creating interesting image distortion, similar to viewing an image through the eye of a fish.

Travel shooting

Produces background image blur that emphasizes the motion of the main subject.



Photo frame

For adding interesting frame effects to the photo.

Sketch

For taking photos with pencil sketch effect.



1. After selecting the scene type, press the  button to activate.
2. After setting the option, press the  button to confirm the setting and enter the selected Scene Selection mode for shooting.

The main function menu also allows you to adjust the image quality and image size. Please refer to the "Advanced Functions Menu" section on page 21 for detailed instructions.

Blink Detection

Blink Detection is enabled by default unless disabled by the user. When shooting, if a face is detected its eyes closed, the Blink Detection  will appear on the screen to show that a blink was detected.

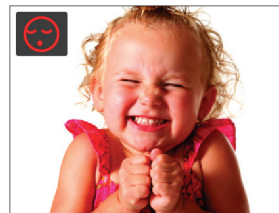

Face Detection

The Face Detection mode will detect and enhance facial features.

1. In Shooting Mode, press the Left/Face Detection button to enable the Face Detection and the () will appear on the LCD.
2. Hold the camera securely, and point the camera towards the subject to start the face detection process. When the camera detects a face, a white rectangular frame will be drawn around the face. (Note: For best results, the face of the subject should be relatively large on the LCD screen, and the subject should be facing the camera as directly as possible.)
3. Press the **Shutter button** halfway to focus on the subject.
4. The frame around the face will turn green when the subject is in focus. Press the Shutter button fully to capture the image.
5. Press the Left/Face Detection button to dissable Face Detection.

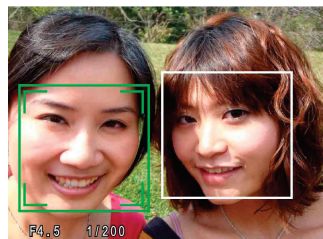
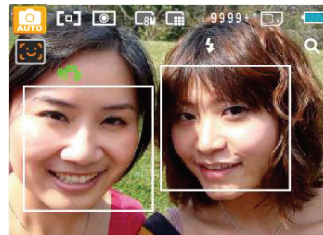

Smile Detection

With the "Smile Detection" feature, the camera automatically detects and captures a person smiling.

1. In Shooting Mode, press the Left/Face Detection button to enable Smile Detection and the (😊) will appear on the LCD.
2. Point the camera at the subject until the subject's face is detected and bracketed by a white frame. Press the Shutter button completely and then release it. The camera will now 'wait' for the subject to smile.
3. When the subject smiles, the camera will automatically and capture the photo.
4. To disable the Smile Detection function, press the Left button, or the Shutter button.

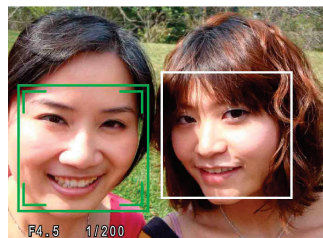
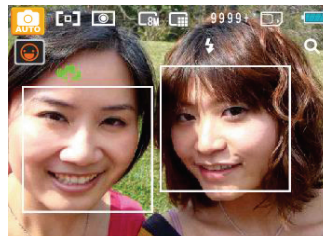

 A face must be detected by the camera in order for smile detection to function correctly.

 For best results, the subject should be framed to occupy most of the screen space.



Viewing Photos and Videos

To view the captured photos and video clips on the LCD screen:

1. Press the  button to enter the **Playback** mode. The last recorded photo or video clip will appear.
2. Use the **Left/Right** navigation buttons to scroll through the photos or video clips stored in the internal memory or memory card.
3. To play a selected video clip, press the  button to enter the movie playback mode.

During video playback, the operating instructions will appear on the screen. Press the Left/Right button, and press the  button for confirmation.

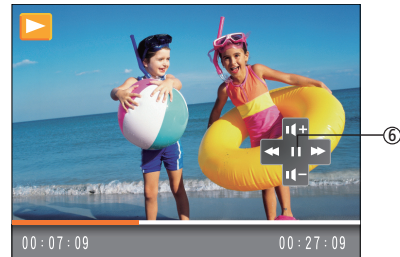
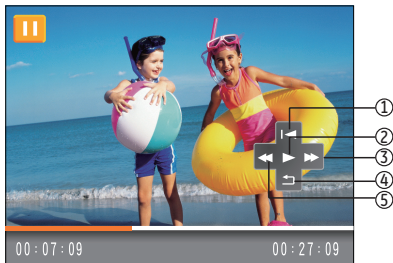

The operating instruction icons are as follows.

- | | | | |
|---|------------------------------------|---|---------------------------|
| 1 | Return to the first frame and play | 4 | Return to the first frame |
| 2 | Play | 5 | Rewind |
| 3 | Fast Forward | 6 | Pause |

When playing a movie, press the Up/Down button to increase or decrease the volume. To mute the audio, press and hold the Down button until the  appears.

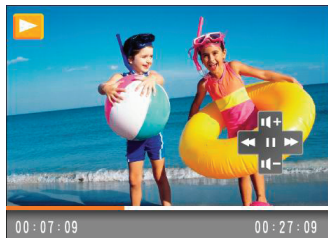



Thumbnail View

In Playback mode, toggle the zoom lever to ( W) and thumbnails of your photos and videos will display on the screen.

1. With each press of the zoom lever either 3x3, 4x4 or date folder thumbnails will display.



2. When 3x3 and 4x4 thumbnails are displayed, use the Up/Down/Left/Right button to select a picture or video clip for viewing; press the  button to return to the original size.
3. When date folder thumbnails are displayed, use the Up/Down button to select the date folder you want to view. Then press the  button to enter the folder and view its images.



4. Use the Up/Down/Left/Right button to select a picture or video clip, press the  button to return to the original size.



The Date Folder is displayed in order based on the shooting date.





If the  indicator appears on the LCD, then a movie file is currently being displayed.

Using Zoom Playback (for still pictures only)

When viewing photos, you can also use the zoom lever to zoom in (2~8) times.

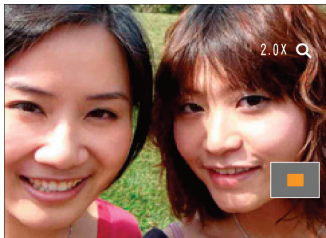
1. Press the  button to enter the **Playback** mode.
2. Use the **Left/Right** navigation buttons to select a photo to magnify.
3. Press the **TQ** section of the zoom wheel to zoom into the photo.
4. When using the zoom wheel to magnify an image. A zoom indicator with your magnified position will appear in the display.



5. Use the navigation buttons to pan across the image.
6. Press the  button to return the image to its original scale.



Movie images cannot be magnified.

Using the Delete Button

In Playback mode, you can press the Down/Delete button to delete pictures or videos.

To delete pictures or videos:

1. Press the  button to enter the Playback mode.
2. Select a picture or video clip you want to delete with the Left/Right button.
3. Press the Down/Delete button and the delete screen will appear.



4. Select Yes or Back with the Up/Down button and press the  button for confirmation.



Erased photos/video clips cannot be recovered.



Please refer to page 51 for instructions on the Delete Menu options.

Still Picture Menu

Mode:      

In any of the above Still Picture modes, press the  button to go to the Still Picture menu.



To adjust each setting:

1. In the Still Picture menu, switch between different Photo Setup or Camera Setup pages using the Left/Right button, to select the page with the function you want to adjust and press the Down button.



2. Press the Up/Down buttons to select the function.
3. Then press the  or Right button to enter the submenu.



4. Press the Up/Down button to select an option or press the Left or  button to return to the menu.
5. Press the  button to confirm the setting and return to the previous page.

 After selecting a function, you can press the Up button to return to the Still Picture menu for other Photo Setup or Camera Setup pages. Or you can press the Down button several times to move to the next setup menu page.

Refer to the following pages for more details about each setting.

AF Mode (Auto-Focus mode)

Use this setting to control the auto-focus mechanism while taking pictures.

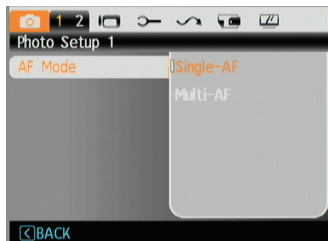

Two options are available:

- **Single-AF:** The focus frame appears on the center of the LCD screen to focus on the subject.
- **Multi-AF:** The camera shall focus correctly for multiple parts of the object.

AF-Assist Beam

This option can turn on or turn off the AF assist lamp. The AF assist lamp assists the camera in focusing correctly in low light conditions. It is not recommended that this be turned off or the camera may not focus correctly.



Continuous AF

The camera continuously focuses on a moving subject such as a sports player.



Expo Metering (Exposure Metering)

This setting determines what part of the picture the camera uses to determine the correct exposure for the whole picture.



Three options are available:

- Spot
- Center-Weight
- AiAE (Artificial Intelligence AE)

Continuous Shot

Use this setting to perform continuous shooting. After entering this mode, you can shoot multiple images by pressing and holding down the shutter button.

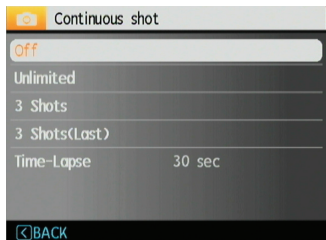

There are five available options:

- **OFF:** Turn off the Continuous Shot function.
- **Continuous shooting:** Press and hold the shutter button to shoot continuously until you release the shutter or until the memory card has run out of space.
- **3 shot:** Capture up to 3 consecutive pictures.
- **3 shots (Last):** Capture pictures continuously until the Shutter button is released. Only the last 3 shots will be recorded.

- **Time Lapse:** Automatically capture pictures at predefined intervals.



The flash is designed not to work in this mode in order to enable quick succession of shots.

Date Imprint

Include a Date/Time stamp in the photo image. There are three options available:



- Off
- Date
- Date and Time

Quick Review

This setting refers to the quick photo review immediately after taking a picture. The picture stays on the LCD screen for an adjustable period of time.



Four options are available:

- Off
- 1 sec
- 2 sec
- 3 sec

Digital Zoom

Use this setting to enable or disable the digital zoom function. When disabled, only the optical zoom is enabled.

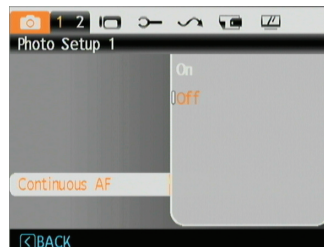

Slow Shutter

In Slow shutter mode, the shutter will remain open as long as the Shutter button is held down. This gives you control over the duration of the exposure. (The slow shutter mode is available only in  manual mode).

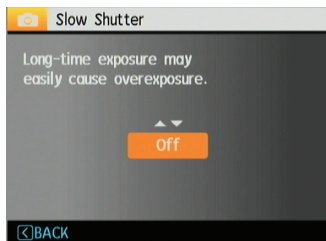



- **Manual:** To set a long exposure time between 2~30 sec.



The use of tripod is recommended for prolonged exposure times.

Movie Menu

Mode: 

In the Movie mode, press the  button to access the Movie Setup menu.

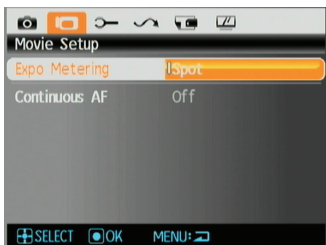

To configure each setting:

1. In the Menu screen, switch between the Movie Setup or different Camera Setup pages using the Left/Right button, select the page with the function you want to adjust and press the Down button.

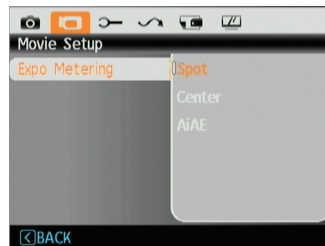

2. Press the Up/Down arrow button to select the function to be set, and Press the  or Right button to enter the submenu.



3. Press the Up/Down button to select an option or the Left or  button to return to the menu.
4. Press the  button to confirm the setting and return to the previous menu.

Refer to the following pages for more details about each setting.

Continuous AF

The camera continuously focuses on a moving subject such as a sports player.



Expo Metering (Exposure Metering)

This setting determines what part of the picture the camera uses to determine the correct exposure for the whole picture.

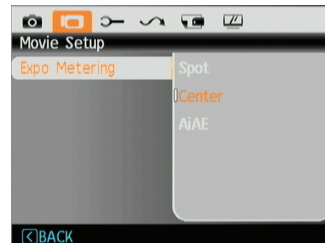

Three options are available:

- Spot
- Center
- AiAE (Artificial Intelligence AE)

Playback Menu

Mode : ▶

In Playback mode, press the  button to enter the **Playback** menu.



Please refer to the following sections for detailed instructions on the various menu options.

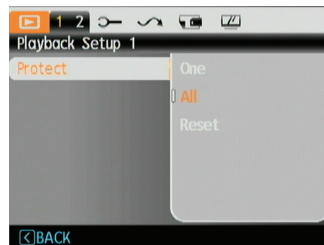

Protect

To prevent pictures or videos from being accidentally erased, use this setting to lock one or all of the files.



To protect/unprotect a picture or video:

1. Use the Up/Down arrow button and select Protect. then press the  or Right button to enter the submenu.

- Use the Up/Down button and select "One" to protect individual photos or movies; or select "All" to protect all photos and movies stored in the memory card. Press the  button to confirm and enter the photo/movie protection interface.
- Press the  button and select Yes to lock displayed photos or videos, or select Unprotect to unlock them, then press the Up/Down button and select Back to return to the playback menu.



 Selecting "reset" will un-protect all previously protected photos and videos.

Delete

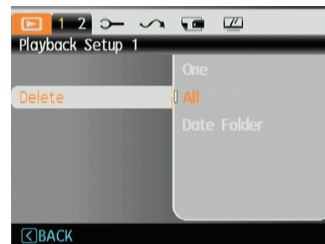
There are three ways to delete files.





• Delete One:



- In the Delete setting, select **Delete One** and then press the  or **Right** button.
- Press the Left/Right button to locate the photo or video to be deleted. Press the Up/Down button to select item (Yes: to delete the file or, Cancel: to return to previous menu) and then press  to confirm.

• Delete All:

1. In the Delete setting, select **Delete All** and then press the  or **Right** button.
2. Use the Up/Down button and select Yes to delete all files, or select Cancel to return to the menu.

• Delete Date Folder:

1. In the Delete option, press the  or button after selecting date folder.
2. Use the Up/Down button to select a Date Folder to be deleted, press  to confirm, press the Up/Down button to select item (Yes: to delete the file or, Cancel: to return to the menu) and then press  to confirm.

 The “” indicator means a file is protected. File protection must be removed first before a file can be deleted.

 Deleting files will cause DPOF settings to be reset.

DPOF (Digital Print Order Format)

DPOF allows you to record a selection of pictures that you would like to print, and will save your selection in the memory card, so that you can simply hand your memory card to a photo kiosk without having to tell them which photos you would like to print.



Trim

The Trim setting allows you to trim an area of a selected photo and save it as a new photo.

To trim a picture:

1. Select the **Trim** setting from the  menu.
2. Using the **Left/Right** buttons, locate the photo that you want to trim and have it displayed on the LCD.
3. Select “Yes” to confirm trimming, then use the zoom wheel and direction buttons to select the part to be cut.



4. Press  button and ‘Save Changes?’ will appear. Select “O” to confirm changes and save it as a new image, or select “X” to cancel changes and return to the previous menu.





The image can not be cropped again when it is cropped to 640X480.

HDR-High Dynamic Range

With the HDR function, pictures that are overexposed may be corrected by optimizing the highlights and lowlights captured to more accurately represent the actual scene.

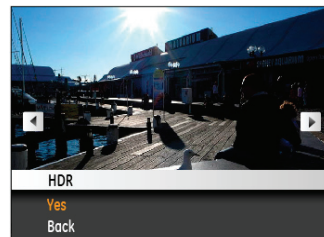
1. Select the HDR setting in the  menu as described previously.
2. Press the Left and Right button to find pictures you want to optimize and then select Confirm to perform HDR optimization or select Return to go back to Playback menu.



3. After HDR optimizing, the image will be saved as another file with the  icon as a prompt, the original file will still remain in the memory.

Resize

This setting allows you to resize a picture to a specified resolution, and saves it as a new picture.

1. Select the **Resize** setting from the **Playback** menu as described previously.

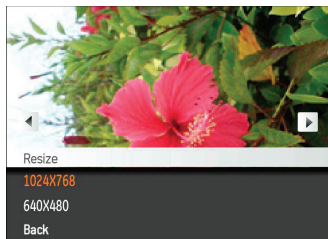

2. Use the **Left/Right** navigation buttons to select a picture to resize.
3. Use the **Up/Down** navigation buttons to select a resolution (**1024X768** or **640X480**) to resize the image or **Back** to cancel and return to the **Playback** menu.
4. Press the **(FUNC/OK)** button to confirm the setting.

 Resizing an image creates a new file that contains the image in the size you select. The file with the original image also remains in the memory.

Rotate

You can use this setting to change the picture orientation of the picture.

1. Select the **Rotate** setting from the **Playback** menu as described previously.
2. Use the **Left/Right** navigation buttons to select a picture to rotate.
3. Use the **Up/Down** navigation buttons to select the direction of rotation or **Back** to cancel and return to the **Playback** menu.

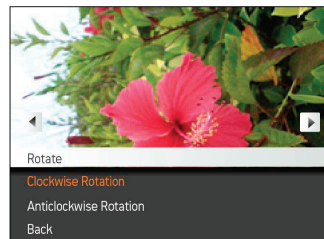

4. Press the **(FUNC/OK)** button to confirm the setting.

 The panorama picture and video cannot be rotated.

 Revolved file will replace the original one.

Red-eye Reduction

Use this setting to remove red eye in your photos.

1. Select the **Red-eye Reduction** in the **Playback** menu as described previously.
2. Use the **Left/Right** button to select the picture from which red eye needs to be removed.
3. Use the **Up/Down** navigation buttons and select **Yes** to fix the selected image or **Back** to cancel and return to the **Playback** menu.

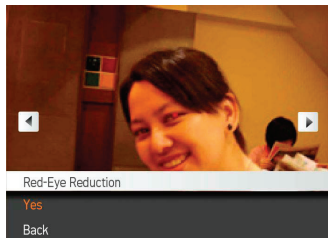

4. Press the **MENU/OK** button to confirm the setting.

 For best results, the face of the subject should be relatively large on the LCD screen, the subject should be facing the camera as directly as possible, and the eyes should be as large as possible.

 If there is no red eyes in the image, press **MENU/OK** button after selecting "Yes"; such prompt will appear on the screen: red eye is not detected!

Display Setup

Mode: 



Press **MENU** button in Playback mode to enter Display Setup menu.





Refer to the following sections for details of every setting.

Slideshow

This setting allows you to view all the stored pictures as a slideshow.

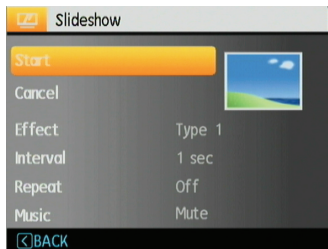
1. Select Slide Show menu, then press the  or Right button to enter the slide show setup interface.
2. Press the Up/Down button to select effect, interval, repeat or music, and press the  or Right button to enter and adjust settings. press the  button to confirm settings.





3. Use the Up/Down navigation buttons and select **Start** to run the slideshow or **Cancel** to return to the Playback menu.
4. Press the  button to confirm the setting.

Wallpaper Settings

Use this setting to use your favorite picture to use as a background on the LCD screen.

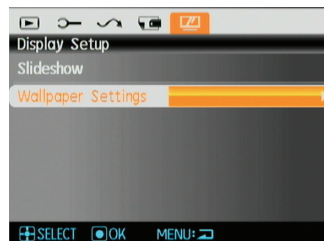

1. Press the Down button to select the Wallpaper Setting menu.

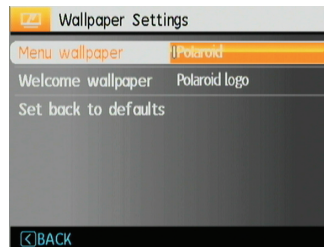

2. Press the  or Right button to enter the wallpaper setup interface.



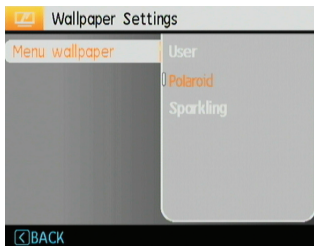

Menu Wallpaper:

Use the Up/Down button to select the Menu Wallpaper option, then press the  button to confirm or press the Left button to return to last page, and press  to exit the menu.



- User
- Polaroid
- Sparkling

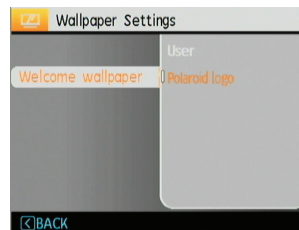

Startup Screen:

Use the Up/Down button to select the Startup Screen option, press  to confirm or press the Left button to the return to last page, and press  to exit the menu.



- User
- Polaroid logo

BackTo Default:

Use the Up/Down button and select Set Back To Default, then press  to confirm or press the Left button to return to last page, and press  to exit the menu.

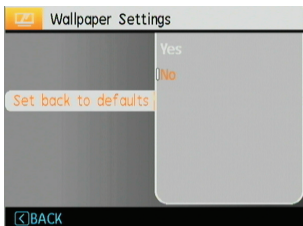

- Yes
- No

Setup Menu

Mode :        

The Setup menu for the camera is available in all modes. Each menu page can be selected by pressing the  button and switching between menus with the Left/Right button.



To adjust the settings:

1. Select the menu page with the function you want to adjust and press the Down button.

2. Switch between different functions with the Up/Down button.
3. Press the  or Right button to enter the submenu.

 After selecting a function option, you can press the Up button to return to the menu for other Camera Setup pages. Or you can press the Down button to switch to the next menu page.

Refer to the following pages for more details about each setting.



Beep

Use this setting to adjust beep volume, shutter button, self timer, power on, and power off tones.

To change these settings:

1. Select the **Beep** setting from the **Setup** menu as described previously.
2. Use the **Up/Down** navigation buttons to switch between volume, shutter tone, key tone, self-timer tone, and power tone options.



3. Press the  or Right button to enter, and Press the Up/Down button to adjust volume and change various sounds, then Press the  button to confirm the setting.

LCD Brightness

Use this setting to adjust the brightness of your LCD screen.

1. Select the **LCD Brightness** setting from the **Setup** menu as described previously.
2. Select auto or adjust the brightness level using the Left/Right button, and press the  button to confirm the setting.

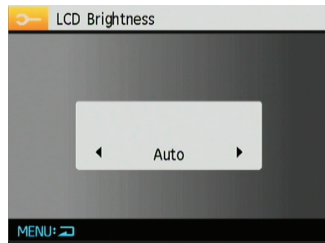

Power Saver

This setting allows you to save power and get the maximum possible running time for your battery. Follow the steps below to turn off the LCD screen and camera automatically after a period of inactivity.

1. Select the **Power Saver** setting from the **Setup** menu as described previously.
2. Press the Up/Down button to select either screen power or camera power, then press the  or Right button to enter.

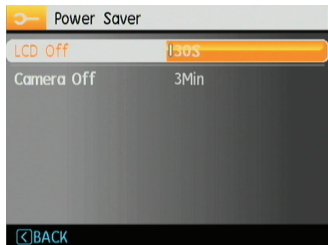



3. Press the Up/Down button to adjust the selected item. Both items have the following options:

- LCD off:
On, 30 sec, 1 Min, 2 Min
 - Camera off:
On, 3 Min, 5 Min, 10 Min
4. Press the  button to confirm.

Zone

The Zone setting is a useful function on your overseas trips. This feature enables you to display the local time on the LCD screen while you are overseas.

1. Select the **Zone** setting from the **Setup** menu as described previously. The world time screen will appear.
2. Use the **Up/Down** navigation buttons to switch between the hometown () and travel destination () fields.
3. Use the **Left/Right** navigation buttons to select a city close to the desired time zone. Then press the  button to confirm.



Date/Time

See “Setting the Date and Time” section on page 16.

Language

See “Setting the Language” section on page 15.

File and Software

Format Memory

Please note: formatting enables you to delete all contents in the memory card and built-in memory, including protected photo and movie files.

To use this setting:

1. Select Format Memory in the File and Software menu.
2. Use the Up/Down navigation buttons to select Yes or No. Then press the  button to confirm.

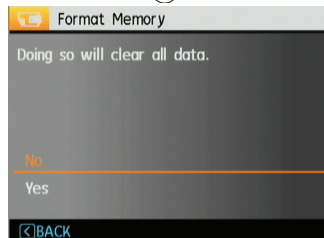

3. Select **Yes**, and the camera will format the selected media.
4. Please note that when you perform the Format Memory function, it only formats the active memory. If a memory card is inserted, the memory card is active and will be formatted. If there is no memory card, the internal memory is active and the internal memory will be formatted. Formatting the memory card will not automatically format the internal memory.

File Numbering

After you take a picture or video clip, the camera will save it in a sequential number. You can use this to reset the file numbering to 1. (When more than 999 images are on the memory card, the use of this feature will have no effect).

1. Select the File Name in File and Software menu.
2. Select the option with the Up/Down button and press the  button for confirmation.

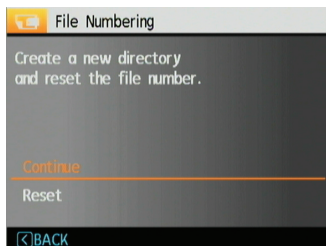

Copy to Card (Copy internal memory to memory card)

Use this setting to copy the files stored in the internal memory to the memory card.

1. Select the **Copy to memory card** in the File and Software menu.
2. Use the **Up/Down** navigation buttons to select **Yes** or **No**. Then press the  button to confirm.

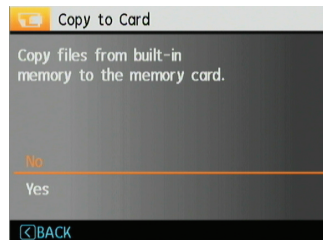

Reset Settings

Use this setting to restore the camera to its default settings.

1. Select **Reset Settings** in the File and Software menu.
2. Use the **Up/Down** navigation buttons to select **Yes** or **No**. Then press the  button to confirm.

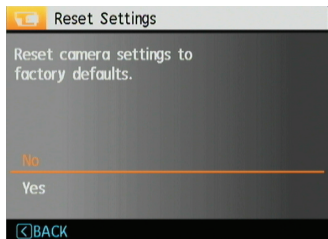

FW Version (Firmware Version)

Use this setting to view the camera's firmware version.

1. Select the **FW Version** in the File and Software menu.
2. If you have uploaded the latest firmware version to your SD card, upgrade accordingly as necessary.

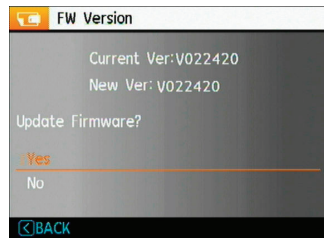

Video System

Use this setting to configure your video system to your current area.

1. Select the **Video System** in the Connection **Transmission** menu.
2. Use the **Up/Down** navigation buttons to select **NTSC** or **PAL**. Then press the  button to confirm.

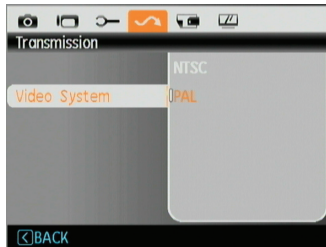

The video output signal can be switched to NTSC or PAL to accommodate different regional standards. The appropriate setting will vary between regions.

NTSC: USA, Canada, Taiwan, Japan, etc.

PAL: Europe, Asia (excluding Taiwan), Oceania, etc.

Note: The TV output will not perform properly if an incorrect video system is selected.

Connect Your Camera to an HDMI TV to View Videos

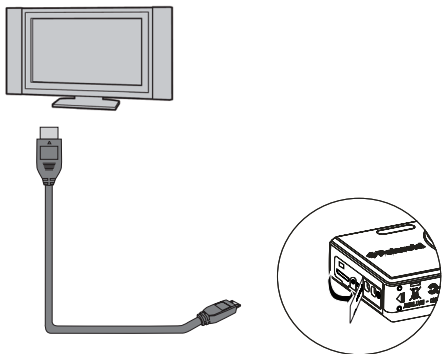

HDMI (High Definition Multimedia Interface), is a fully digital audio/video transmission interface, through which uncompressed audio and video signals are transmitted.

Direct transmission of digital video signals to your TV reduces conversion loss and improves image quality.



Connecting the camera to an HDMI TV

1. Use a high-definition output terminal cable (optional) to connect your camera to an HDMI compliant TV.
2. The camera will automatically determine if the connected display supports 1080i resolution. If the display supports the resolution, select the resolution you prefer in the menu shown on the camera and the monitor will display the images at the specified resolution. If the monitor does not support the resolution, it will automatically display images at the highest resolution possible.
3. Once an output format is selected, the LCD screen in the camera will go blank (although it is still on) and your TV will then display the images and menus.



-  Note that your camera and TV should be turned off before connecting them.
-  Refer to your TV instruction manual for information on what resolution sizes it will support. The resolution and output formats that are not supported will be grayed out on the camera's LCD screen.

Connecting to a PC

Use the USB cable supplied with your camera to copy (transfer) pictures to a computer.

Setting the USB Mode

Since the camera's USB port can be set to connect with either a PC or a Printer, the following steps will ensure that the camera is correctly configured to connect with a PC. The USB mode is set to PC by default.

1. Enter the Transmission menu and select USB Mode with the Up/Down button, then press the  or Right button to enter.
2. Use the **Up/Down** navigation buttons and select **PC**.
3. Press the  button to confirm the setting.

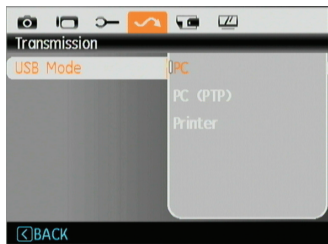

Transferring Files to Your PC

The computer will automatically detect the camera as a removable drive. Double-click the **My Computer** icon on the desktop to locate the removable drive and to copy the folders and files in the drive to a directory on your PC as you would copy any other folder or file.

By using the USB cable, you can transfer the captured photos and videos to a PC. Follow the steps below to connect the camera to a PC.

1. Make sure both the camera and PC are turned on.
2. Connect one end of the supplied USB cable to the USB/AV OUT port on your camera.
3. Connect the other end of the cable to an available USB port on your PC.

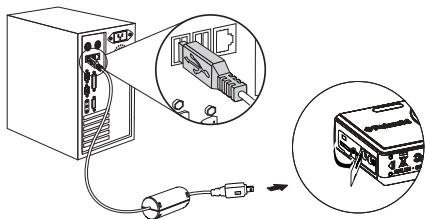

4. Disconnect the camera once the transfer is completed.

If the USB option is set to [PC] :

Turn the camera off and disconnect the USB cable.

If the USB option is set to [PC (PTP)] :

Remove the camera from the system as described below before turning the camera off and disconnecting the USB cable.

Windows operating system (Windows 2000, Windows XP, Windows Vista, Windows 7.)

Click the [Safely remove the hardware] icon and remove the USB connector according to the displayed menu.



Macintosh

Drag the untitled icon to the Trash. ("Untitled")



Specifications



Design and specifications are subject to change without notice.

Active Image Sensor Pixels		16.07 Megapixels
Total Image Sensor Pixels		16.56 Megapixels [1/2.33"CCD]
Lens	Focal Length	5.1mm (Wide) — 40.8mm (Tele)
	[35mm film equivalent]	[28mm (Wide) — 224mm (Tele)]
	F number	F3.3 (Wide) — F5.8 (Tele)
	Lens Construction	8 groups 12 elements
	Optical Zoom	8x
	Focusing Range	Normal: (Wide) 60cm ~ ∞, (Tele) 100cm ~ ∞ Macro: 5cm ~ ∞ (Wide Only)
Anti-Handshake		Optical Image Stabilization
Digital Zoom		6x Digital Zoom (Combined Zoom: 48x)

Number of Recording Pixels	Still Image	16MP: 4608×3456, (16:9)12MP: 4608×2592, 8MP: 3264×2448, 5MP: 2592×1944, 3MP: 2048×1536, (16:9)2MP: 1920×1080, 0.3MP: 640×480
	Movie	720p30, 720p15, VGA, QVGA
Image Compression		Best, Fine, Normal
DCF, DPOF (Ver1.1) Support		Yes
File Format	Still Image	Exif 2.2 (JPEG)
	Movie	Movie Format: MOV (H.264), Audio: G.711 [Monaural]
Shooting Modes		Auto, ASCN, Manual, Portrait, Panorama, Movie, Scene (Sport, Children, Indoor, Leaf, Beach, Text, Party, ID, Fisheye, Panning Shot, Photo Frame, Sketch, Snow, Sunset, Fireworks, Glass, Museum, Landscape, Night Landscape, Night Portrait)
Detection Features		Face, Smile, Blink
Red-Eye Removal		Yes
HDR		Yes (Post-Processing)
Panorama Capture	Still Image	Yes (Horizontal)
	View Angle	0° ~ 355°

LCD Display	3.0inch (230k Pixels)
ISO Sensitivity	Auto, ISO64/100/200/400/800/1600(4M)/3200(4M)
AF Method	Single AF, Multi-AF (TTL 9-point), Face-Detection, AF Assist Light (On/Off)
Exposure Metering Method	Artificial Intelligence AE (AiAE), Center-Weighted Average, Spot (Fixed to Center of Frame), Face AE
Exposure Control Method	Program AE (AE-Lock Available)
Exposure Compensation	±2EV in 1/3 Step Increments
Shutter Speed	1/2000 ~ 4 Seconds (Manual: 30 Seconds)
Continuous Shooting	Yes
Playback Modes	Single Photo, Index (9/16 Thumbnails), Slide Show, Movie, Date
	Zoom (Approx. 2x ~ 8x), Histogram Display
White Balance Control	Auto (AWB), Daylight, Cloudy, Fluorescent, Fluorescent CWF, Incandescent, Manual

Flash	Flash Modes	Auto, Red-Eye Reduction, Forced Flash, No Flash, Slow Synchro, Red-Eye Reduction + Slow Synchro
	Shooting Range	(Wide) Approx. 0.5m ~ 5.0m (ISO800) (Tele) Approx. 0.5m ~ 2.8m (ISO800)
Recording Media		Internal Memory: Approx. 43MB
		SD/SDHC Card (Up to 32GB Support) [Nonsupport MMC Card]
Other Features		ExifPrint Support, Multi-Language Support (26 Languages)
Jacks		AV-OUT/USB 2.0 (Mini 8 pin USB), HDMI (Type C)
Power		Rechargeable Li-ion Battery D016-05-8023, 3.7V 650mAh
Shooting Capability (Battery Performance)		Approx. 180 Shots (Based on CIPA Standards)
Operation Environment		Temperature: 0~40°C, Humidity: 0 ~ 90%
Dimensions (WxHxD)		Approx. 100.4x57.9x24.5mm (Based on CIPA Standards)
Weight		Approx. 145g (Body Only)
Supplied Accessories		Rechargeable Li-ion Battery, USB Cable, Battery Charger
		Wrist Strap, CD-ROM
		Quick Start Guide, Warranty Card

Error messages

Messages	Explanation
Card error	<ul style="list-style-type: none"> • The memory card is not formatted.
Card full	<ul style="list-style-type: none"> • The memory card is full and cannot store any new images.
Picture error	<ul style="list-style-type: none"> • The picture is not captured correctly. • The picture is corrupted.
No picture	<ul style="list-style-type: none"> • There are no images in the memory card or in the internal memory.
Lens error	<ul style="list-style-type: none"> • The lens is probably stuck and the camera will power off automatically.
System error	<ul style="list-style-type: none"> • Unexpected error encountered.
Write protect	<ul style="list-style-type: none"> • The write protection switch in the memory card is set to the "LOCK" position.
Out of the range	<ul style="list-style-type: none"> • When pictures were taken in Panorama mode, the direction of movement was incorrect.

Messages	Explanation
Card is not formatted, format?	<ul style="list-style-type: none">• Confirm whether the memory card should be formatted.
This image cannot be deleted	<ul style="list-style-type: none">• The picture or video you are trying to delete is protected.
Warning!! Camera recording, please wait.	<ul style="list-style-type: none">• No other actions allowed to perform during video/audio recording.
Warning!! Battery exhausted.	<ul style="list-style-type: none">• The battery is out of charge.
This file cannot be played back	<ul style="list-style-type: none">• The picture format cannot be recognized by the camera.
No connection	<ul style="list-style-type: none">• The camera is not connected to the printer correctly.
Print error	<ul style="list-style-type: none">• There is a problem with camera or printer.
Cannot print	<ul style="list-style-type: none">• Check that the printer is out of paper or out of ink.• Check if the printer has a paper jam.

Troubleshooting

Problem	Possible causes	Solution
Camera does not turn on.	<ul style="list-style-type: none"> • The battery has run out. • The battery is not inserted correctly. 	<ul style="list-style-type: none"> • Replace with a fully charged battery.
Camera turns off suddenly during operation.	<ul style="list-style-type: none"> • The battery has run out. 	<ul style="list-style-type: none"> • Replace with a fully charged battery.
Images and video files cannot be saved.	<ul style="list-style-type: none"> • The memory card is full. 	<ul style="list-style-type: none"> • Replace the memory card with a new one. • Delete unwanted images. • Unlock the memory card.
No picture is taken when pressing the Shutter button.	<ul style="list-style-type: none"> • The memory card is full. • No available space to store the files. • The mode dial is in Playback mode. 	<ul style="list-style-type: none"> • Replace the memory card with a new one or format the current memory card. • Delete unwanted images. • The memory card is locked.

Problem	Possible causes	Solution
Write to memory card slowly	<ul style="list-style-type: none"> • When movie above HD is recorded into the memory card below Class 4, perhaps it is too slow to continue recording. 	<ul style="list-style-type: none"> • Please select HCSD or shoot after formatting this card.
Cannot write to the memory card	<ul style="list-style-type: none"> • Memory card is in write-protection state. • When shooting or recording, write-protection interruption phenomenon in the memory card (such as due to too slow storage etc.) leads that you can not continue to shoot or record. 	<ul style="list-style-type: none"> • Please replace a memory card. • Please shoot again.
Too many movies to process	<ul style="list-style-type: none"> • The number of pictures or binders in the memory card exceeded the specifications, so the playback of data folder can not be displayed. 	<ul style="list-style-type: none"> • Delete needless files. • Transfer the files in the memory card to other area.
Exceed maximum folder number in the memory card	<ul style="list-style-type: none"> • "Yes" is selected for "File No" menu in the Menu (see P63 for detailed instructions). 	<ul style="list-style-type: none"> • Transfer the files in the memory card to other area. • Set "No" for "File No".

Customer Care

Questions? Need some help?

This manual should help you understand your new product. If you still have questions, call our help line or visit www.polaroid.com.

Manufactured by

plawa-feinwerktechnik GmbH & Co. KG
Bleichereistraße 18
73066 UHINGEN
Germany

Polaroid and Polaroid & Pixel are trademarks of PLR IP Holdings, LLC, used under license. All other trademarks are the property of the respective owner, who has not sponsored, endorsed or approved this product. PLR IP Holdings, LLC does not manufacture this product or provide any Manufacturer's Warranty or support.

PLR IP Holdings, LLC, its licensees and affiliates, fully support all electronic waste initiatives. As responsible stewards of the environment, and to avoid violating established laws, you should properly dispose of this product in compliance with all applicable regulations, directives or other governances in the area where you reside. Please check with local authorities or the retailer where you purchased this

product to determine a location where you can appropriately dispose of the product.

You may also go to www.polaroid.com/support to learn more about the specific laws in your area and to locate a collection facility near your home.

If your electronic device has internal memory on which personal or other confidential data may be stored, you may want to perform a data sanitization process before you dispose of your device to assure another party cannot access your personal data. Data sanitization varies by the type of product and its software, and you may want to research the best sanitization process for your device before disposal. You may also check with your local recycling facility to determine their data sanitization procedures during the recycling process.



Questions?
Need some help?
This manual will help you
enjoy your new product



If you still have questions
call our help line:
1-877-456-6055



or visit us at:
www.polaroid.com